

***emtek***<sup>TM</sup>

HEAVY EQUIPMENT MAT  

---

DESIGN GUIDE



PORTABLE ROADWAY SYSTEMS, INC.

**emtek**<sup>™</sup>  
HEAVY EQUIPMENT MAT

**emtek** is the engineered mat for enabling heavy equipment to operate on unstable or soft soil conditions.

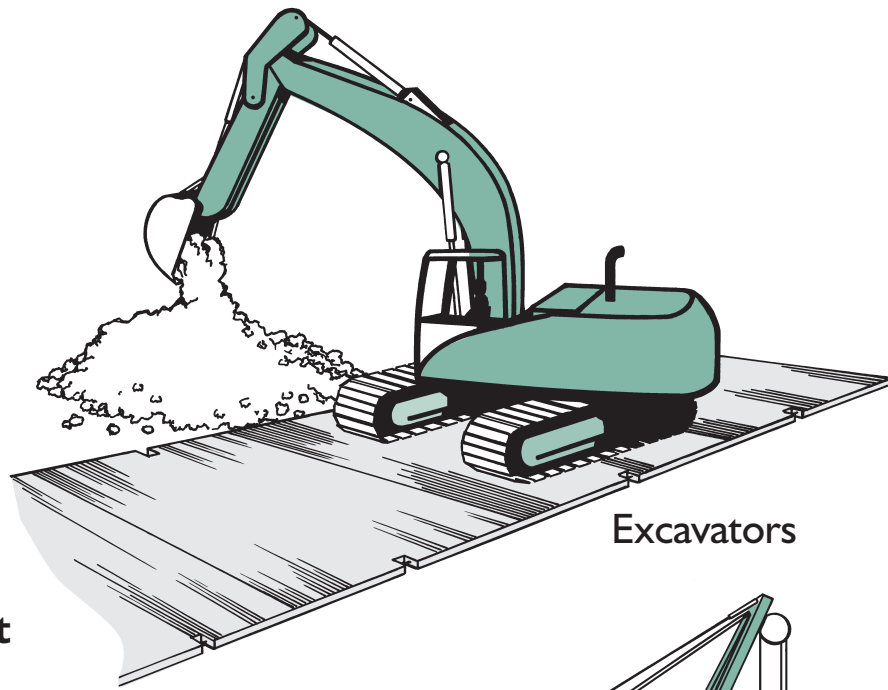

Excavators

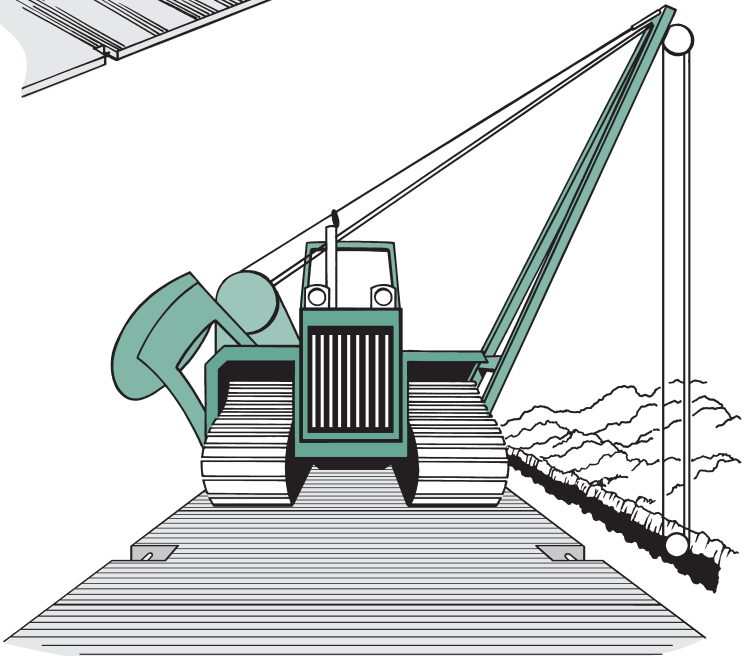

Pipe Layers

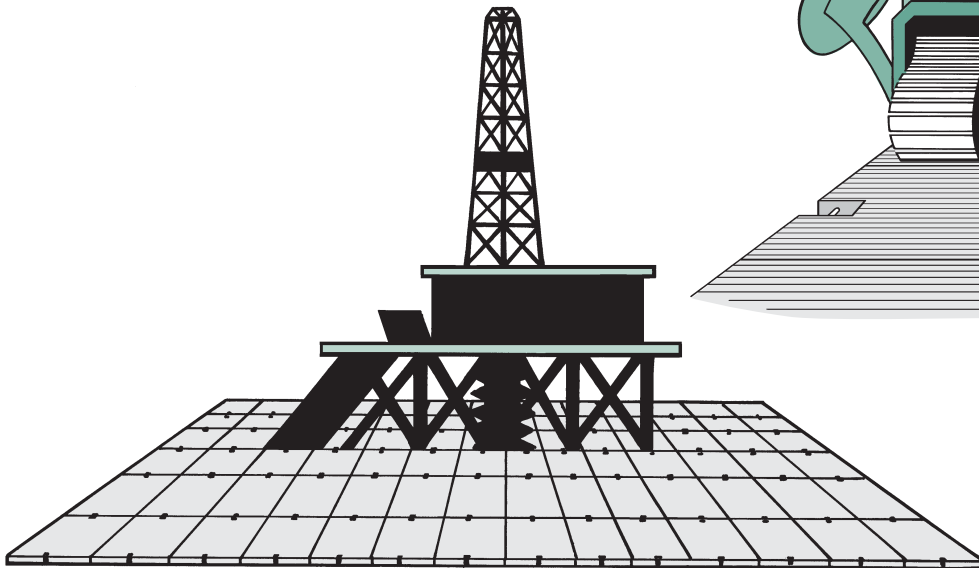

Drilling Rigs

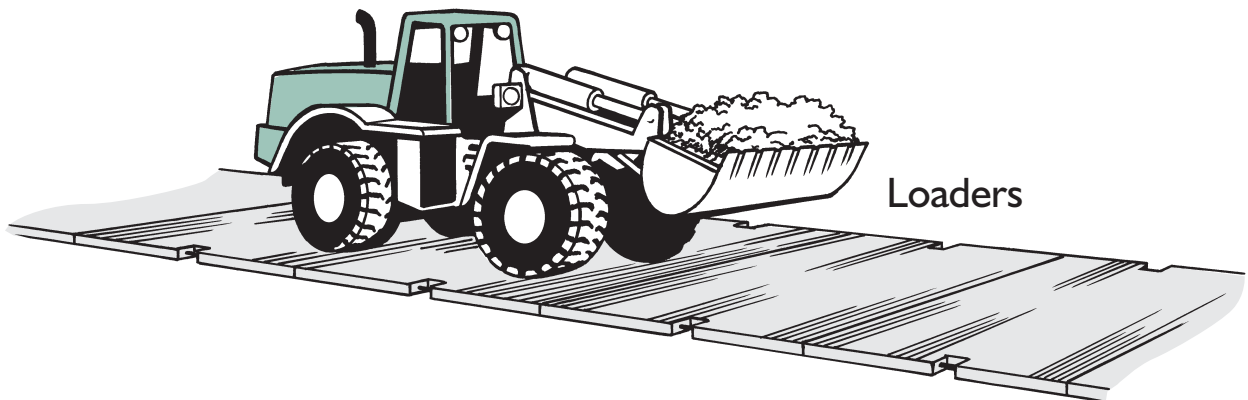

Loaders

# TABLE OF CONTENTS

---

<b>How to Use This Guide</b> .....	1
<b>Caution to Users</b> .....	1
<b>Introduction</b> .....	2
<b>Storage &amp; Handling</b> .....	2
<b>emtek Specifications</b> .....	3
<b>Comparison</b> .....	3
<b>Weight Table</b> .....	3
<b>Uniform Bearing On Soil</b>	
Load Diagrams .....	4
Table I-A, Load Criteria Uniform Bearing On Soil Type “A” 4” Deflection .....	5
Table I-B, Load Criteria Uniform Bearing On Soil Type “A” 4” Deflection .....	6
Table II-A, Load Criteria Uniform Bearing On Soil Type “B” 4” Deflection .....	7
Table II-B, Load Criteria Uniform Bearing On Soil Type “B” 4” Deflection .....	8
Table III-A, Load Criteria Uniform Bearing On Soil Type “C” 4” Deflection .....	9
Table III-B, Load Criteria Uniform Bearing On Soil Type “C” 4” Deflection .....	10
Table IV-A, Load Criteria Uniform Bearing On Soil Type “A” 2” Deflection .....	11
Table IV-B, Load Criteria Uniform Bearing On Soil Type “A” 2” Deflection .....	12
Table V-A, Load Criteria Uniform Bearing On Soil Type “B” 2” Deflection .....	13
Table V-B, Load Criteria Uniform Bearing On Soil Type “B” 2” Deflection .....	14
Table VI-A, Load Criteria Uniform Bearing On Soil Type “C” 2” Deflection .....	15
Table VI-B, Load Criteria Uniform Bearing On Soil Type “C” 2” Deflection .....	16
<b>Design Properties</b> .....	17
<b>Load Diagrams Bearing At Ends Of Span</b> .....	17
<b>Table VII, Load Criteria Uniform Bearing At Ends Of Span</b> .....	18
<b>Heavy Lift Section Properties</b> .....	19
<b>Mat Load Diagrams</b> .....	19
<b>Table VIII, Heavy Lift Sections</b> .....	20
<b>Table VIII, Heavy Lift Sections Cont’d</b> .....	21
<b>Notes &amp; Calculations</b> .....	22-23

## How to use this guide...

**emtek** mats are engineered to support specified loads. The tables in this guide show allowable loads. Each mat has been proof loaded to 1.5 times the allowable load at the manufacturing facility to certify these values.

The following pages show different loading configurations for the mats. Generally pneumatic tired vehicles will be represented by the 6' wide loading configurations (Load Case 1 and Load Case 4). Tracked vehicles will generally be represented by the 9' wide loading configurations (Load Case 2 and Load Case 5). When one wheel or track is on one mat, the single load configurations shown in Load Case 3 and Load Case 6 will be applicable. In all cases the loads shown in the tables are in thousands of pounds (Kips). To get pounds simply multiply the number in the cell by 1000.

It is important to note that the loads are associated with one foot of mat width. If the footprint of the tire is 2' long then the allowable load can be multiplied by two. This is especially important when considering applications for tracked vehicles that can distribute loads along track lengths up to 16' or longer.

There are three sets of tables. The first two sets (Tables 1-3 and Tables 4-6) are for applications where the entire length of the mat is sitting on soil, or some continuous surface (Uniform Bearing). The last table (Table 7) is for applications where the mat will only be supported on the ends. In applications of Uniform Bearing, we have shown different allowable loads for different soil conditions (Soil Type "A", "B", and "C"). These soil conditions are described in the notes on each page of the tables. It is important to choose the soil condition that most closely approximates the conditions that will be supporting the mats, as this will affect the allowable loads.

The first (Tables 1-3) and second (Tables 4-6) set of tables show different deflection preferences. If you would like to see no more than 2" of deflection on the matted surface, Tables 4-6 should be considered. If a deflection up to 4" is acceptable, then Tables 1-3 should be considered. In some cases loads are limited by the strength of the product, and maximum deflections are not allowed. In this case the deflection at the maximum allowable load is indicated.

Table 7 assumes an adequate bearing surface on each end with bearing lengths as shown in the Loading Diagrams. Table 7 shows maximum allowable loads as well as the deflections associated with those loads.

Table 8 was developed specifically for crane and heavy lift application. This table deals with 8" to 24" thick mats under extremely high loading conditions. The loads, deflections, and soil reaction figures assume a Subgrade Modulus of 8K/ft<sup>2</sup>/in.

Certainly construction applications with heavy equipment will result in unique loads and loading configurations. If you have any questions regarding your unique situation please feel free to call us at **800-762-8267**.

### Caution to Users:

The design properties and strength characteristics of the **emtek** product are verified at the time of manufacture. During the service life of the product, use conditions will reduce the load carrying capacity of the product. If there are any questions as to whether the strength of the product has been compromised during handling, storage, aggressive use, etc., please feel free to contact us so we can help assess any potential degrade.

# Introduction

This Design Guide is intended to provide design information to enable you to determine how **emtek** can best serve your needs. **emtek** is an engineered, laminated wood mat that is made from indigenous Southern hardwoods in Sheridan, Arkansas. By eliminating or distributing natural defects, such as wane, knots, and checking, **emtek** is superior in strength when compared to solid sawn material twice its depth and weight.

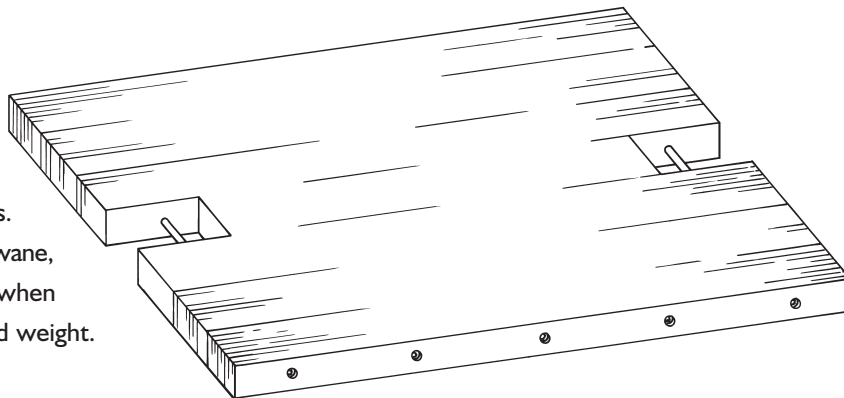

## Durability

**emtek** is engineered to withstand the abuse of today's industrial construction sites. Control of raw material density in the manufacturing process ensures that **emtek** has a hard, impact resistant surface. The laminating process creates a composite structure that resists fracture.

## Strength

Predictable, reliable strength is a necessity when the safety of workers and equipment assets are at stake. Patented construction creates a work platform that has engineering design values that exceed all sawn woods identified by the National Design Standard (NDS 2004). Every **emtek** component is proof loaded by machine to ensure that the finished mat will meet the strict design criteria and quality standards established by AHC.

## Consistency

Uniform product dimensions with a consistent finish create a work surface that helps contractors reduce workplace hazards.

## Storage and Work Environment Considerations

**emtek** mats are valuable to the contractor, and proper storage can extend the service life for many years. Product should be stored in an environment with good drainage. Stacking mats with stickers between layers provides an avenue for air movement that can reduce the effects of decay caused by prolonged exposure to moisture.

Wood is a natural polymer that exhibits good resistance to chemical exposure; however, extended contact with strong acids ( $\text{pH} < 3$ ) or strong bases ( $\text{pH} > 9$ ) can cause wood to degrade and compromise the structural integrity of the product. The resins used in **emtek** construction are thermoset polymers that are highly resistant to chemical attack and will degrade slower than the wood when exposed to high chemical concentrations. Chemical MSDS sheets should be referenced if the product's exposure is suspected.

Prolonged exposure to temperature above  $150^{\circ}\text{F}$  can cause the wood to degrade and should be avoided to ensure that the product performs at the designed levels.

# emtek Specifications

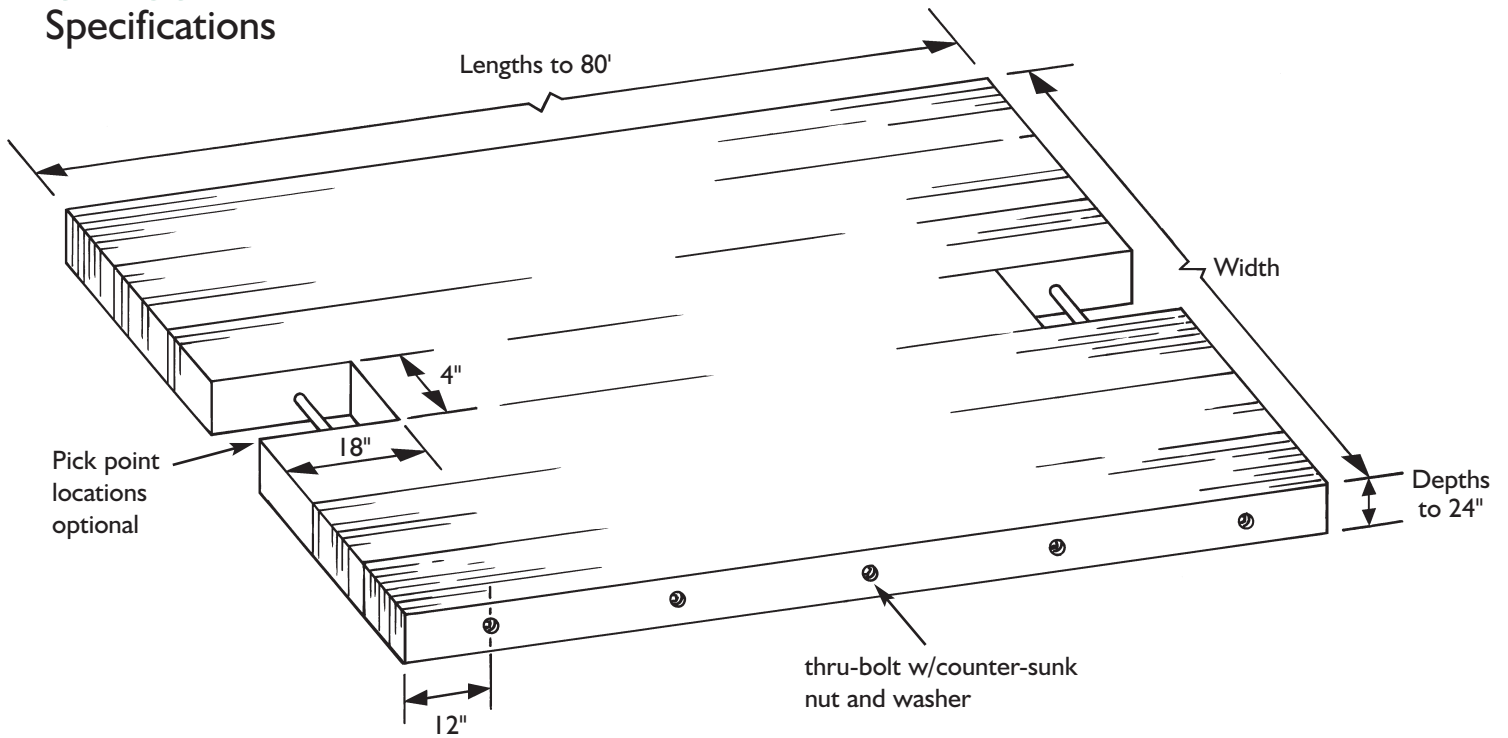

SVE Portable Roadway Systems

emtek mats

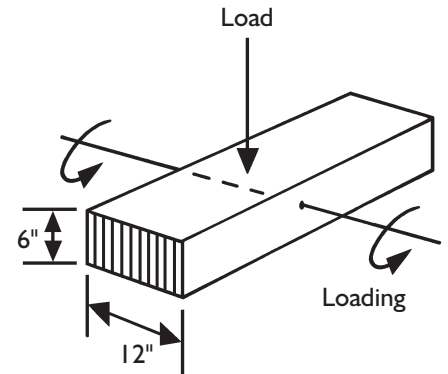
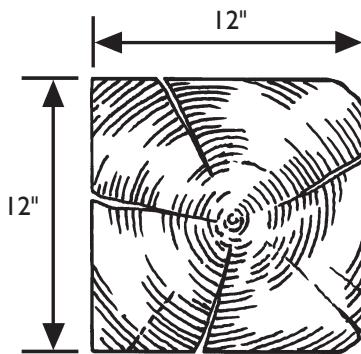
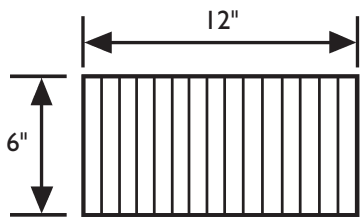

Though less than half the weight, 6" x 12" **emtek** is 10% stronger than a grade No. 2 12" x 12" white oak. Each beam produced by AHC has a rated structural capacity verified by intense quality control standards.

emtek Weight in Pounds										
emtek mat Size	3 1/2"		4 1/2"		5 1/2"		6 1/2"		7 1/2"	
	Dry	Wet	Dry	Wet	Dry	Wet	Dry	Wet	Dry	Wet
4' x 12'	630	700	810	900	990	1100	1170	1300	1350	1500
4' x 16'	848	933	1080	1200	1320	1467	1560	1733	1800	2000
4' x 20'	1050	1167	1350	1500	1650	1833	1950	2167	2250	2500
4' x 24'	1260	1400	1620	1800	1980	2200	2340	2600	2700	3000

**Note:** Assumed density: dry 47 pcf; wet 52 pcf

# Load Diagrams

## Uniform Bearing On Soil

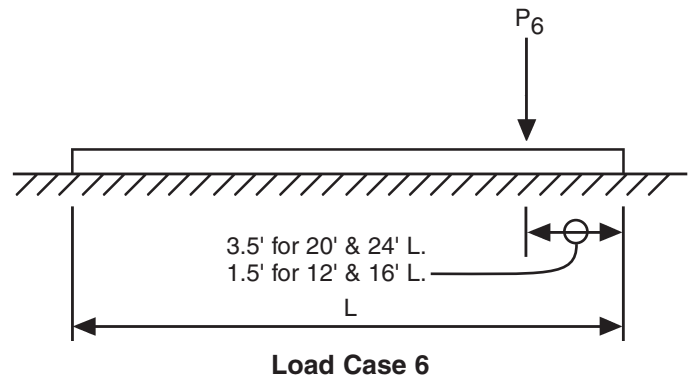
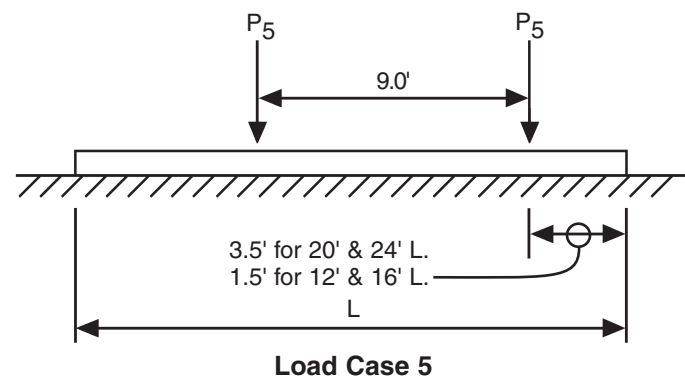
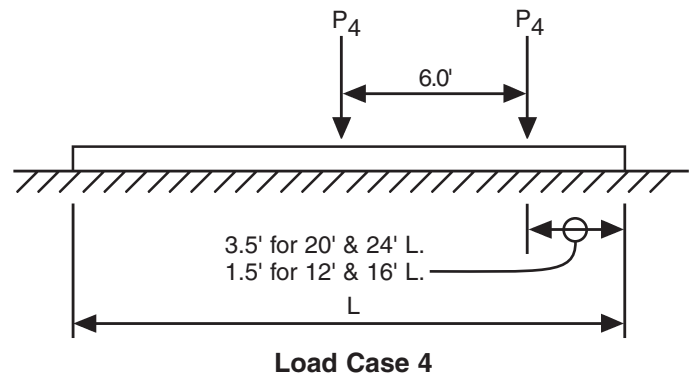
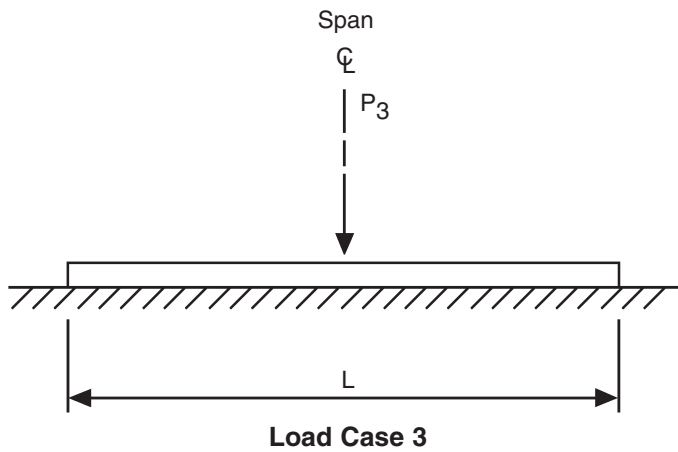
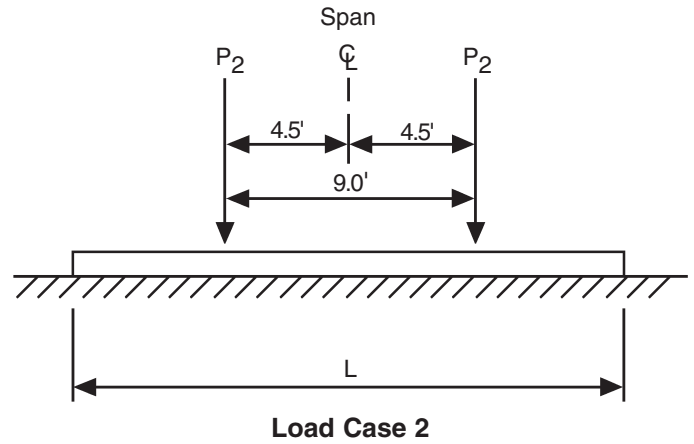
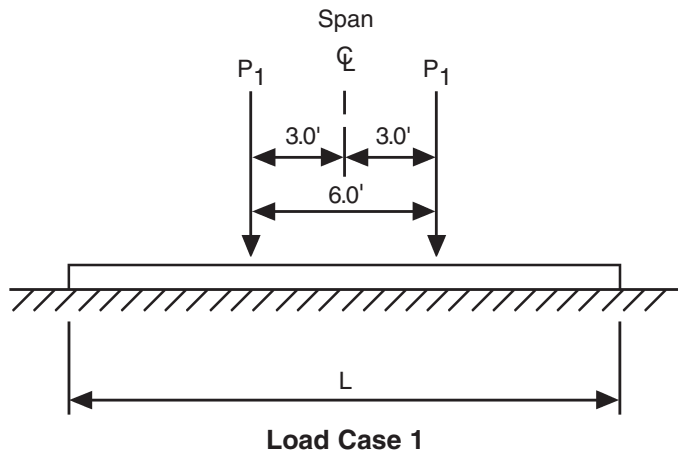

**Table I-A**  
**Load Criteria (centered loading)**  
**Uniform Bearing On Soil Type "A"**

Load Per Linear Foot Of Width, K = Kip = 1,000 Lbs

Length	Thickness	Load Case 1			Load Case 2			Load Case 3		
Feet	Inches	P Load Kips	Defl. Inches	Bearing PSI	P Load Kips	Defl. Inches	Bearing PSI	P Load Kips	Defl. Inches	Bearing PSI
24	2.75	3.4	4.0	4.2	4.4	4.0	4.2	4.0	3.1	3.5
	3.5	3.8	4.0	4.2	4.5	4.0	4.2	5.4	4.0	4.2
	4.5	4.3	4.0	4.2	5.1	4.0	4.2	7.3	4.0	4.2
	5.5	4.8	4.0	4.2	5.4	4.0	4.2	8.5	4.0	4.2
	6.5	5.2	4.0	4.2	5.8	4.0	4.2	9.6	4.0	4.2
	7.5	5.6	4.0	4.2	6.0	4.0	4.2	10.5	4.0	4.2
20	2.75	3.4	4.0	4.2	4.7	4.0	4.2	4.0	3.1	3.5
	3.5	3.6	4.0	4.2	4.7	4.0	4.2	5.3	3.7	3.5
	4.5	4.1	4.0	4.2	4.9	4.0	4.2	7.0	4.0	4.2
	5.5	4.5	4.0	4.2	5.2	4.0	4.2	8.1	4.0	4.2
	6.5	4.9	4.0	4.2	5.3	4.0	4.2	8.9	4.0	4.2
	7.5	5.1	4.0	4.2	5.4	4.0	4.2	9.6	4.0	4.2
16	2.75	3.5	4.0	4.2	3.9	4.0	4.2	4.0	3.1	3.5
	3.5	3.6	4.0	4.2	4.3	4.0	4.2	5.4	3.7	3.5
	4.5	4.0	4.0	4.2	4.4	4.0	4.2	6.8	4.0	4.2
	5.5	4.2	4.0	4.2	4.5	4.0	4.2	7.6	4.0	4.2
	6.5	4.3	4.0	4.2	4.6	4.0	4.2	8.0	4.0	4.2
	7.5	4.4	4.0	4.2	4.6	4.0	4.2	8.4	4.0	4.2
12	2.75	3.1	4.0	4.2	2.1	4.0	3.5	4.4	3.5	3.5
	3.5	3.3	4.0	4.2	2.8	4.0	4.2	5.5	4.0	4.2
	4.5	3.4	4.0	4.2	3.0	4.0	4.2	6.1	4.0	4.2
	5.5	3.4	4.0	4.2	3.2	4.0	4.2	6.4	4.0	4.2
	6.5	3.4	4.0	4.2	3.3	4.0	4.2	6.5	4.0	4.2
	7.5	3.4	4.0	4.2	3.3	4.0	4.2	6.6	4.0	4.2

**NOTES FOR LOAD TABLES**

1. Loads listed in Tables 1 through 6 are based on a uniform soil bearing analysis using a simplified elastic soil procedure where the soil is assumed to act as a line of springs spaced one foot apart along the length with resistance directly proportional to settlement. (Similar to the subgrade modulus procedures for slab and paving design, except, with higher deflections allowed).

Type "A" (SGM-1) soil has a spring constant of 144 pounds per square foot, per inch settlement. Type "B" (SGM-3) soil has a spring constant of 432 pounds per square foot, per inch of settlement. Type "C" (SGM-5) soil has a spring constant of 720 pounds per square foot, per inch of settlement.

2. Loads listed in Table 7 are based on normal simple span beam design methods. Adequate bearing must be provided at the ends to support the loads.

3. Load duration - Loads listed in all tables are based on a stress increase of 1/3 (33 1/3%) for short duration loading. Where stresses govern the load, applied long term loads should be reduced accordingly and as much as 1/3 less for long term loading or frequent cycles of loading.

4. Load distribution - Load Tables are based on a unit width one foot wide perpendicular to the length. Loads can be assumed distributed over more than one foot depending on the type of load and loading conditions.

5. Edge loading - Load cases 4, 5, & 6 as shown in the load diagrams, are based on off-center loading. Under edge loading conditions the unloaded end of the member will deflect upward and should be considered when using edge loading.

**Table I-B  
Load Criteria (offset loading)  
Uniform Bearing On Soil Type "A"**

Load Per Linear Foot Of Width, K = Kip = 1,000 Lbs

Length	Thickness	Load Case 4			Load Case 5			Load Case 6		
Feet	Inches	P Load Kips	Defl. Inches	Bearing PSI	P Load Kips	Defl. Inches	Bearing PSI	P Load Kips	Defl. Inches	Bearing PSI
24	2.75	3.2	4.0	4.2	3.8	4.0	4.2	2.7	4.0	3.5
	3.5	3.5	4.0	4.2	4.2	4.0	4.2	3.7	4.0	4.2
	4.5	3.5	4.0	4.2	4.2	4.0	4.2	3.7	4.0	4.2
	5.5	3.2	4.0	4.2	3.9	4.0	4.2	3.2	4.0	4.2
	6.5	3.0	4.0	4.2	3.7	4.0	4.2	3.5	4.0	4.2
	7.5	3.0	4.0	4.2	3.7	4.0	4.2	3.7	4.0	4.2
20	2.75	3.2	4.0	4.2	3.8	4.0	4.2	2.7	4.0	3.5
	3.5	3.4	4.0	4.2	4.1	4.0	4.2	3.4	4.0	4.2
	4.5	3.2	4.0	4.2	3.9	4.0	4.2	3.2	4.0	4.2
	5.5	3.1	4.0	4.2	3.8	4.0	4.2	3.1	4.0	4.2
	6.5	3.0	4.0	4.2	3.7	4.0	4.2	3.1	4.0	4.2
	7.5	2.9	4.0	4.2	3.7	4.0	4.2	3.1	4.0	4.2
16	2.75	1.6	4.0	4.2	1.8	4.0	3.5	0.7	4.0	2.8
	3.5	1.9	4.0	4.2	2.3	4.0	4.2	1.4	4.0	4.2
	4.5	1.9	4.0	4.2	2.4	4.0	4.2	1.4	4.0	4.2
	5.5	1.9	4.0	4.2	2.5	4.0	4.2	1.4	4.0	4.2
	6.5	1.9	4.0	4.2	2.5	4.0	4.2	1.4	4.0	4.2
	7.5	1.9	4.0	4.2	2.5	4.0	4.2	1.4	4.0	4.2
12	2.75	1.6	4.0	4.2	1.8	4.0	3.5	0.7	4.0	2.8
	3.5	1.9	4.0	4.2	2.7	4.0	4.2	1.5	4.0	4.2
	4.5	1.9	4.0	4.2	3.0	4.0	4.2	1.5	4.0	4.2
	5.5	1.9	4.0	4.2	3.2	4.0	4.2	1.5	4.0	4.2
	6.5	1.9	4.0	4.2	3.3	4.0	4.2	1.5	4.0	4.2
	7.5	1.9	4.0	4.2	3.3	4.0	4.2	1.5	4.0	4.2

**Determining Loads**

Load tables are subject to interpretation and use for a variety of conditions. For load cases where uniform bearing is used: first the soil strength should be estimated and then using the tables for the various soil types and the load case that compares closest to the load conditions, the thickness and length can be selected; alternatively, for an existing thickness and length the estimated load resistance can be determined from the Tables.

Soil Type "A" (SGM-1) is soft soil and in theory a 200 lb person standing on a one foot by one foot (1ft<sup>2</sup>) block would settle into the surface 1/3".

For Soil Type "B" (SGM-3) the same 200 lbs on a one foot square would settle 7/16".

For Soil Type "C" (SGM-5) the same 200 lbs on a one foot square would settle 1/4"±.

For estimating soil strength using simplified bearing tests as described above, results should be based on incremental loads. Divide the resulting pressure in pounds per square inch by the settlement, and the results averaged to determine an estimated SGM.

For areas where geotechnical reports are required the geotechnical engineering should be requested to provide an estimated bearing capacity of the bearing strata, and if practical, in the form of subgrade modulus for settlement estimated in the range of one to two inches.

**Table II-A**  
**Load Criteria (centered loading)**  
**Uniform Bearing On Soil Type "B"**

Load Per Linear Foot Of Width, K = Kip = 1,000 Lbs

Length	Thickness	Load Case 1			Load Case 2			Load Case 3		
Feet	Inches	P Load Kips	Defl. Inches	Bearing PSI	P Load Kips	Defl. Inches	Bearing PSI	P Load Kips	Defl. Inches	Bearing PSI
24	2.75	6.8	2.8	8.3	6.2	2.0	6.3	5.5	1.8	5.6
	3.5	8.8	3.6	11.1	8.9	2.7	8.3	7.4	2.1	6.3
	4.5	10.7	4.0	11.8	12.1	3.4	10.4	9.8	2.4	6.9
	5.5	11.6	4.0	11.8	14.6	4.0	11.8	12.5	2.6	7.6
	6.5	12.7	4.0	11.8	15.1	4.0	11.8	15.3	2.8	8.3
	7.5	13.7	4.0	11.8	15.9	4.0	11.8	18.2	3.0	9.0
20	2.75	6.8	2.8	8.3	6.2	2.0	6.3	5.3	1.8	5.6
	3.5	8.7	3.5	10.4	9.0	2.5	7.6	7.4	2.1	6.3
	4.5	10.6	4.0	11.8	13.0	3.7	11.1	9.8	2.4	6.9
	5.5	11.6	4.0	11.8	14.5	4.0	11.8	12.3	2.6	7.6
	6.5	12.6	4.0	11.8	15.1	4.0	11.8	15.3	2.8	8.3
	7.5	13.6	4.0	11.8	15.5	4.0	11.8	18.8	3.1	9.0
16	2.75	6.8	2.8	8.3	7.7	2.8	8.3	5.3	1.8	5.6
	3.5	8.8	3.6	11.1	11.2	3.6	11.1	7.0	2.1	6.3
	4.5	10.7	4.0	11.8	13.0	4.0	11.8	9.6	2.3	6.9
	5.5	11.5	4.0	11.8	13.4	4.0	11.8	12.6	2.7	8.3
	6.5	12.1	4.0	11.8	13.5	4.0	11.8	16.5	3.1	9.0
	7.5	12.6	4.0	11.8	13.6	4.0	11.8	21.1	3.7	11.1
12	2.75	9.1	4.0	11.8	4.3	4.0	9.7	5.3	1.8	5.6
	3.5	9.7	4.0	11.8	6.7	4.0	11.8	7.1	2.1	6.9
	4.5	10.0	4.0	11.8	7.9	4.0	11.8	10.5	2.6	7.6
	5.5	10.1	4.0	11.8	8.7	4.0	11.8	14.8	3.4	10.4
	6.5	10.2	4.0	11.8	9.2	4.0	11.8	18.5	4.0	11.8
	7.5	10.2	4.0	11.8	9.5	4.0	11.8	19.1	4.0	11.8

**NOTES FOR LOAD TABLES**

1. Loads listed in Tables 1 through 6 are based on a uniform soil bearing analysis using a simplified elastic soil procedure where the soil is assumed to act as a line of springs spaced one foot apart along the length with resistance directly proportional to settlement. (Similar to the subgrade modulus procedures for slab and paving design, except, with higher deflections allowed).

Type "A" (SGM-1) soil has a spring constant of 144 pounds per square foot, per inch settlement. Type "B" (SGM-3) soil has a spring constant of 432 pounds per square foot, per inch of settlement. Type "C" (SGM-5) soil has a spring constant of 720 pounds per square foot, per inch of settlement.

2. Loads listed in Table 7 are based on normal simple span beam design methods. Adequate bearing must be provided at the ends to support the loads.

3. Load duration - Loads listed in all tables are based on a stress increase of 1/3 (33 1/3%) for short duration loading. Where stresses govern the load, applied long term loads should be reduced accordingly and as much as 1/3 less for long term loading or frequent cycles of loading.

4. Load distribution - Load Tables are based on a unit width one foot wide perpendicular to the length. Loads can be assumed distributed over more than one foot depending on the type of load and loading conditions.

5. Edge loading - Load cases 4, 5, & 6 as shown in the load diagrams, are based on off-center loading. Under edge loading conditions the unloaded end of the member will deflect upward and should be considered when using edge loading.

**Table II-B  
Load Criteria (offset loading)  
Uniform Bearing On Soil Type "B"**

Load Per Linear Foot Of Width, K = Kip = 1,000 Lbs

Length	Thickness	Load Case 4			Load Case 5			Load Case 6		
Feet	Inches	P Load Kips	Defl. Inches	Bearing PSI	P Load Kips	Defl. Inches	Bearing PSI	P Load Kips	Defl. Inches	Bearing PSI
24	2.75	6.8	2.9	9.0	6.1	2.2	6.9	6.5	2.7	8.3
	3.5	10.0	4.0	11.8	9.2	3.0	9.0	9.8	3.4	10.4
	4.5	10.2	4.0	11.8	12.7	4.0	11.8	10.6	4.0	11.8
	5.5	10.5	4.0	11.8	12.5	4.0	11.8	10.1	4.0	11.8
	6.5	10.0	4.0	11.8	12.0	4.0	11.8	9.8	4.0	11.8
	7.5	9.5	4.0	11.8	11.9	4.0	11.8	9.7	4.0	11.8
20	2.75	6.8	2.9	9.0	6.1	2.2	6.9	6.5	2.7	8.3
	3.5	9.9	4.0	11.8	9.0	2.9	9.0	9.7	3.4	10.4
	4.5	10.1	4.0	11.8	12.4	4.0	11.8	10.5	4.0	11.8
	5.5	10.3	4.0	11.8	12.4	4.0	11.8	10.1	4.0	11.8
	6.5	9.9	4.0	11.8	12.0	4.0	11.8	9.8	4.0	11.8
	7.5	9.4	4.0	11.8	11.6	4.0	11.8	9.6	4.0	11.8
16	2.75	4.3	4.0	10.4	4.3	4.0	9.7	2.0	4.0	8.3
	3.5	5.7	4.0	11.8	6.2	4.0	11.8	4.4	4.0	11.8
	4.5	5.8	4.0	11.8	6.8	4.0	11.8	4.4	4.0	11.8
	5.5	5.8	4.0	11.8	7.1	4.0	11.8	4.4	4.0	11.8
	6.5	5.8	4.0	11.8	7.4	4.0	11.8	4.4	4.0	11.8
	7.5	5.8	4.0	11.8	7.5	4.0	11.8	4.4	4.0	11.8
12	2.75	4.3	4.0	10.4	4.3	4.0	9.7	2.0	4.0	8.3
	3.5	5.8	4.0	11.8	6.8	4.0	11.8	4.5	4.0	11.8
	4.5	5.8	4.0	11.8	7.9	4.0	11.8	4.5	4.0	11.8
	5.5	5.8	4.0	11.8	8.7	4.0	11.8	4.5	4.0	11.8
	6.5	5.8	4.0	11.8	9.2	4.0	11.8	4.5	4.0	11.8
	7.5	5.8	4.0	11.8	9.5	4.0	11.8	4.5	4.0	11.8

**Determining Loads**

Load tables are subject to interpretation and use for a variety of conditions. For load cases where uniform bearing is used: first the soil strength should be estimated and then using the tables for the various soil types and the load case that compares closest to the load conditions, the thickness and length can be selected; alternatively, for an existing thickness and length the estimated load resistance can be determined from the Tables.

Soil Type "A" (SGM-1) is soft soil and in theory a 200 lb person standing on a one foot by one foot (1ft<sup>2</sup>) block would settle into the surface 1/3".

For Soil Type "B" (SGM-3) the same 200 lbs on a one foot square would settle 7/16".

For Soil Type "C" (SGM-5) the same 200 lbs on a one foot square would settle 1/4"±.

For estimating soil strength using simplified bearing tests as described above, results should be based on incremental loads. Divide the resulting pressure in pounds per square inch by the settlement, and the results averaged to determine an estimated SGM.

For areas where geotechnical reports are required the geotechnical engineering should be requested to provide an estimated bearing capacity of the bearing strata, and if practical, in the form of subgrade modulus for settlement estimated in the range of one to two inches.

**Table III-A  
Load Criteria (centered loading)  
Uniform Bearing On Soil Type "C"**

Load Per Linear Foot Of Width, K = Kip = 1,000 Lbs

Length	Thickness	Load Case 1			Load Case 2			Load Case 3		
Feet	Inches	P Load Kips	Defl. Inches	Bearing PSI	P Load Kips	Defl. Inches	Bearing PSI	P Load Kips	Defl. Inches	Bearing PSI
24	2.75	7.7	2.0	9.7	6.7	1.4	6.9	6.0	1.4	6.9
	3.5	10.0	2.4	11.8	10.0	1.9	9.7	8.6	1.6	8.3
	4.5	13.3	3.2	16.0	15.5	2.8	13.9	11.3	1.9	9.7
	5.5	15.9	3.5	17.4	18.0	3.0	15.3	14.3	2.0	9.7
	6.5	18.7	3.8	18.8	21.9	3.6	18.1	17.5	2.2	11.1
	7.5	20.9	4.0	20.1	25.0	4.0	20.1	20.8	2.3	11.8
20	2.75	7.7	2.0	9.7	6.7	1.4	6.9	6.0	1.4	6.9
	3.5	10.4	2.6	13.2	9.8	1.9	9.7	8.2	1.6	8.3
	4.5	13.3	3.2	16.0	14.2	2.5	12.5	11.4	1.9	9.7
	5.5	15.9	3.5	17.4	19.0	3.2	16.0	14.2	2.0	9.7
	6.5	18.8	3.9	19.4	24.3	4.0	20.1	17.3	2.2	11.1
	7.5	20.9	4.0	20.1	25.1	4.0	20.1	20.7	2.3	11.8
16	2.75	7.6	2.0	9.7	7.7	1.8	9.0	6.0	1.4	6.9
	3.5	9.9	2.5	12.5	11.2	2.3	11.8	8.2	1.6	8.3
	4.5	13.5	3.2	16.0	18.4	3.5	17.4	10.9	1.8	9.0
	5.5	17.6	3.9	20.1	22.0	4.0	20.1	14.0	2.0	9.7
	6.5	19.2	4.0	20.1	22.3	4.0	20.1	17.7	2.2	11.1
	7.5	20.1	4.0	20.1	22.5	4.0	20.1	22.2	2.6	13.2
12	2.75	9.9	2.7	13.2	6.3	3.9	16.0	6.0	1.4	6.9
	3.5	12.5	3.1	15.3	9.4	3.7	18.8	7.9	1.6	8.3
	4.5	16.4	4.0	20.1	11.9	4.0	20.1	11.3	1.9	9.7
	5.5	16.7	4.0	20.1	13.5	4.0	20.1	15.4	2.3	11.8
	6.5	16.9	4.0	20.1	14.6	4.0	20.1	20.8	2.8	13.9
	7.5	17.0	4.0	20.1	15.4	4.0	20.1	27.0	3.5	17.4

**NOTES FOR LOAD TABLES**

1. Loads listed in Tables 1 through 6 are based on a uniform soil bearing analysis using a simplified elastic soil procedure where the soil is assumed to act as a line of springs spaced one foot apart along the length with resistance directly proportional to settlement. (Similar to the subgrade modulus procedures for slab and paving design, except, with higher deflections allowed).

Type "A" (SGM-1) soil has a spring constant of 144 pounds per square foot, per inch settlement. Type "B" (SGM-3) soil has a spring constant of 432 pounds per square foot, per inch of settlement. Type "C" (SGM-5) soil has a spring constant of 720 pounds per square foot, per inch of settlement.

2. Loads listed in Table 7 are based on normal simple span beam design methods. Adequate bearing must be provided at the ends to support the loads.

3. Load duration - Loads listed in all tables are based on a stress increase of 1/3 (33 1/3%) for short duration loading. Where stresses govern the load, applied long term loads should be reduced accordingly and as much as 1/3 less for long term loading or frequent cycles of loading.

4. Load distribution - Load Tables are based on a unit width one foot wide perpendicular to the length. Loads can be assumed distributed over more than one foot depending on the type of load and loading conditions.

5. Edge loading - Load cases 4, 5, & 6 as shown in the load diagrams, are based on off-center loading. Under edge loading conditions the unloaded end of the member will deflect upward and should be considered when using edge loading.

**Table III-B  
Load Criteria (offset loading)  
Uniform Bearing On Soil Type "C"**

Load Per Linear Foot Of Width, K = Kip = 1,000 Lbs

Length	Thickness	Load Case 4			Load Case 5			Load Case 6		
Feet	Inches	P Load Kips	Defl. Inches	Bearing PSI	P Load Kips	Defl. Inches	Bearing PSI	P Load Kips	Defl. Inches	Bearing PSI
24	2.75	7.4	2.0	9.7	6.7	1.6	7.6	6.9	1.8	9.0
	3.5	10.0	2.5	12.5	10.0	2.0	9.7	10.0	2.1	10.4
	4.5	14.7	3.5	17.4	14.9	2.8	13.9	15.9	3.3	16.7
	5.5	17.2	4.0	20.1	20.1	3.8	18.8	18.4	4.0	20.1
	6.5	17.4	4.0	20.1	20.9	4.0	20.1	16.6	4.0	20.1
	7.5	16.9	4.0	20.1	20.2	4.0	20.1	16.2	4.0	20.1
20	2.75	7.4	2.0	9.7	6.7	1.6	7.6	6.9	1.8	9.0
	3.5	11.4	2.8	13.9	9.9	2.0	9.7	10.0	2.1	10.4
	4.5	14.6	3.5	17.4	14.2	2.8	13.9	15.5	3.3	16.7
	5.5	17.1	4.0	20.1	18.9	3.6	18.1	17.1	4.0	20.1
	6.5	17.2	4.0	20.1	20.8	4.0	20.1	16.7	4.0	20.1
	7.5	16.7	4.0	20.1	20.2	4.0	20.1	16.0	4.0	20.1
16	2.75	6.7	4.0	17.4	6.4	4.0	16.0	3.5	4.0	13.9
	3.5	9.5	4.0	20.1	9.6	4.0	20.1	7.2	4.0	20.1
	4.5	9.6	4.0	20.1	10.7	4.0	20.1	7.2	4.0	20.1
	5.5	9.7	4.0	20.1	11.4	4.0	20.1	7.2	4.0	20.1
	6.5	9.7	4.0	20.1	11.9	4.0	20.1	7.2	4.0	20.1
	7.5	9.7	4.0	20.1	12.2	4.0	20.1	7.2	4.0	20.1
12	2.75	6.7	4.0	17.4	6.3	3.9	16.0	3.5	4.0	13.9
	3.5	9.5	4.0	20.1	9.4	3.7	18.8	7.5	4.0	20.1
	4.5	9.7	4.0	20.1	11.9	4.0	20.1	7.5	4.0	20.1
	5.5	9.7	4.0	20.1	13.5	4.0	20.1	7.5	4.0	20.1
	6.5	9.7	4.0	20.1	14.6	4.0	20.1	7.5	4.0	20.1
	7.5	9.8	4.0	20.1	15.3	4.0	20.1	7.5	4.0	20.1

**Determining Loads**

Load tables are subject to interpretation and use for a variety of conditions. For load cases where uniform bearing is used: first the soil strength should be estimated and then using the tables for the various soil types and the load case that compares closest to the load conditions, the thickness and length can be selected; alternatively, for an existing thickness and length the estimated load resistance can be determined from the Tables.

Soil Type "A" (SGM-1) is soft soil and in theory a 200 lb person standing on a one foot by one foot (1ft<sup>2</sup>) block would settle into the surface 1 3/8".

For Soil Type "B" (SGM-3) the same 200 lbs on a one foot square would settle 7/16".

For Soil Type "C" (SGM-5) the same 200 lbs on a one foot square would settle 1/4"±.

For estimating soil strength using simplified bearing tests as described above, results should be based on incremental loads. Divide the resulting pressure in pounds per square inch by the settlement, and the results averaged to determine an estimated SGM.

For areas where geotechnical reports are required the geotechnical engineering should be requested to provide an estimated bearing capacity of the bearing strata, and if practical, in the form of subgrade modulus for settlement estimated in the range of one to two inches.

**Table IV-A**  
**Load Criteria (centered loading)**  
**Uniform Bearing On Soil Type "A"**

Load Per Linear Foot Of Width, K = Kip = 1,000 Lbs

Length	Thickness	Load Case 1			Load Case 2			Load Case 3		
Feet	Inches	P Load Kips	Defl. Inches	Bearing PSI	P Load Kips	Defl. Inches	Bearing PSI	P Load Kips	Defl. Inches	Bearing PSI
24	2.75	1.7	2.0	2.1	2.2	2.0	2.1	2.6	2.0	2.1
	3.5	1.9	2.0	2.1	2.2	2.0	2.1	2.7	2.0	2.1
	4.5	2.1	2.0	2.1	2.5	2.0	2.1	3.6	2.0	2.1
	5.5	2.4	2.0	2.1	2.7	2.0	2.1	4.2	2.0	2.1
	6.5	2.6	2.0	2.1	2.9	2.0	2.1	4.8	2.0	2.1
	7.5	2.8	2.0	2.1	3.0	2.0	2.1	5.2	2.0	2.1
20	2.75	1.7	2.0	2.1	2.3	2.0	2.1	2.6	2.0	2.1
	3.5	1.8	2.0	2.1	2.3	2.0	2.1	2.9	2.0	2.1
	4.5	2.0	2.0	2.1	2.4	2.0	2.1	3.5	2.0	2.1
	5.5	2.2	2.0	2.1	2.6	2.0	2.1	4.0	2.0	2.1
	6.5	2.4	2.0	2.1	2.6	2.0	2.1	4.4	2.0	2.1
	7.5	2.5	2.0	2.1	2.7	2.0	2.1	4.8	2.0	2.1
16	2.75	1.7	2.0	2.1	1.9	2.0	2.1	2.6	2.0	2.1
	3.5	1.8	2.0	2.1	2.1	2.0	2.1	2.9	2.0	2.1
	4.5	2.0	2.0	2.1	2.2	2.0	2.1	3.4	2.0	2.1
	5.5	2.1	2.0	2.1	2.2	2.0	2.1	3.8	2.0	2.1
	6.5	2.1	2.0	2.1	2.3	2.0	2.1	4.0	2.0	2.1
	7.5	2.2	2.0	2.1	2.3	2.0	2.1	4.2	2.0	2.1
12	2.75	1.5	2.0	2.1	1.0	2.0	2.1	2.6	2.0	2.1
	3.5	1.6	2.0	2.1	1.4	2.0	2.1	2.7	2.0	2.1
	4.5	1.7	2.0	2.1	1.5	2.0	2.1	3.0	2.0	2.1
	5.5	1.7	2.0	2.1	1.6	2.0	2.1	3.2	2.0	2.1
	6.5	1.7	2.0	2.1	1.6	2.0	2.1	3.2	2.0	2.1
	7.5	1.7	2.0	2.1	1.6	2.0	2.1	3.3	2.0	2.1

**NOTES FOR LOAD TABLES**

1. Loads listed in Tables 1 through 6 are based on a uniform soil bearing analysis using a simplified elastic soil procedure where the soil is assumed to act as a line of springs spaced one foot apart along the length with resistance directly proportional to settlement. (Similar to the subgrade modulus procedures for slab and paving design, except, with higher deflections allowed).

Type "A" (SGM-1) soil has a spring constant of 144 pounds per square foot, per inch settlement. Type "B" (SGM-3) soil has a spring constant of 432 pounds per square foot, per inch of settlement. Type "C" (SGM-5) soil has a spring constant of 720 pounds per square foot, per inch of settlement.

2. Loads listed in Table 7 are based on normal simple span beam design methods. Adequate bearing must be provided at the ends to support the loads.

3. Load duration - Loads listed in all tables are based on a stress increase of 1/3 (33 1/3%) for short duration loading. Where stresses govern the load, applied long term loads should be reduced accordingly and as much as 1/3 less for long term loading or frequent cycles of loading.

4. Load distribution - Load Tables are based on a unit width one foot wide perpendicular to the length. Loads can be assumed distributed over more than one foot depending on the type of load and loading conditions.

5. Edge loading - Load cases 4, 5, & 6 as shown in the load diagrams, are based on off-center loading. Under edge loading conditions the unloaded end of the member will deflect upward and should be considered when using edge loading.

**Table IV-B**  
**Load Criteria (offset loading)**  
**Uniform Bearing On Soil Type "A"**

Load Per Linear Foot Of Width, K = Kip = 1,000 Lbs

Length	Thickness	Load Case 4			Load Case 5			Load Case 6		
Feet	Inches	P Load Kips	Defl. Inches	Bearing PSI	P Load Kips	Defl. Inches	Bearing PSI	P Load Kips	Defl. Inches	Bearing PSI
24	2.75	1.6	2.0	2.1	1.9	2.0	2.1	1.3	2.0	2.1
	3.5	1.7	2.0	2.1	2.1	2.0	2.1	1.8	2.0	2.1
	4.5	1.7	2.0	2.1	2.1	2.0	2.1	1.8	2.0	2.1
	5.5	1.6	2.0	2.1	1.9	2.0	2.1	1.6	2.0	2.1
	6.5	1.5	2.0	2.1	1.8	2.0	2.1	1.7	2.0	2.1
	7.5	1.5	2.0	2.1	1.8	2.0	2.1	1.8	2.0	2.1
20	2.75	1.6	2.0	2.1	1.9	2.0	2.1	1.3	2.0	2.1
	3.5	1.7	2.0	2.1	2.0	2.0	2.1	1.7	2.0	2.1
	4.5	1.6	2.0	2.1	1.9	2.0	2.1	1.6	2.0	2.1
	5.5	1.5	2.0	2.1	1.9	2.0	2.1	1.5	2.0	2.1
	6.5	1.5	2.0	2.1	1.8	2.0	2.1	1.5	2.0	2.1
	7.5	1.4	2.0	2.1	1.8	2.0	2.1	1.5	2.0	2.1
16	2.75	0.8	2.0	2.1	0.9	2.0	2.1	0.3	2.0	1.4
	3.5	0.9	2.0	2.1	1.1	2.0	2.1	0.7	2.0	2.1
	4.5	0.9	2.0	2.1	1.2	2.0	2.1	0.7	2.0	2.1
	5.5	0.9	2.0	2.1	1.2	2.0	2.1	0.7	2.0	2.1
	6.5	0.9	2.0	2.1	1.2	2.0	2.1	0.7	2.0	2.1
	7.5	0.9	2.0	2.1	1.2	2.0	2.1	0.7	2.0	2.1
12	2.75	0.8	2.0	2.1	1.0	2.0	2.1	0.3	2.0	1.4
	3.5	0.9	2.0	2.1	1.3	2.0	2.1	0.7	2.0	2.1
	4.5	0.9	2.0	2.1	1.5	2.0	2.1	0.7	2.0	2.1
	5.5	0.9	2.0	2.1	1.6	2.0	2.1	0.7	2.0	2.1
	6.5	0.9	2.0	2.1	1.6	2.0	2.1	0.7	2.0	2.1
	7.5	0.9	2.0	2.1	1.6	2.0	2.1	0.7	2.0	2.1

**Determining Loads**

Load tables are subject to interpretation and use for a variety of conditions. For load cases where uniform bearing is used: first the soil strength should be estimated and then using the tables for the various soil types and the load case that compares closest to the load conditions, the thickness and length can be selected; alternatively, for an existing thickness and length the estimated load resistance can be determined from the Tables.

Soil Type "A" (SGM-1) is soft soil and in theory a 200 lb person standing on a one foot by one foot (1ft<sup>2</sup>) block would settle into the surface 1 3/8".

For Soil Type "B" (SGM-3) the same 200 lbs on a one foot square would settle 7/16".

For Soil Type "C" (SGM-5) the same 200 lbs on a one foot square would settle 1/4"±.

For estimating soil strength using simplified bearing tests as described above, results should be based on incremental loads. Divide the resulting pressure in pounds per square inch by the settlement, and the results averaged to determine an estimated SGM.

For areas where geotechnical reports are required the geotechnical engineering should be requested to provide an estimated bearing capacity of the bearing strata, and if practical, in the form of subgrade modulus for settlement estimated in the range of one to two inches.

**Table V-A**  
**Load Criteria (centered loading)**  
**Uniform Bearing On Soil Type "B"**

Load Per Linear Foot Of Width, K = Kip = 1,000 Lbs

Length	Thickness	Load Case 1			Load Case 2			Load Case 3		
Feet	Inches	P Load Kips	Defl. Inches	Bearing PSI	P Load Kips	Defl. Inches	Bearing PSI	P Load Kips	Defl. Inches	Bearing PSI
24	2.75	4.8	2.0	6.3	6.2	2.0	6.3	5.3	1.8	5.6
	3.5	4.9	2.0	6.3	6.6	2.0	6.3	7.0	2.0	6.3
	4.5	5.3	2.0	6.3	7.1	2.0	6.3	8.1	2.0	6.3
	5.5	5.8	2.0	6.3	7.3	2.0	6.3	9.6	2.0	6.3
	6.5	6.3	2.0	6.3	7.5	2.0	6.3	10.9	2.0	6.3
	7.5	6.8	2.0	6.3	7.9	2.0	6.3	12.1	2.0	6.3
20	2.75	4.8	2.0	6.3	6.2	2.0	6.3	5.3	1.8	5.6
	3.5	4.9	2.0	6.3	7.1	2.0	6.3	6.9	2.0	6.3
	4.5	5.3	2.0	6.3	7.0	2.0	6.3	8.1	2.0	6.3
	5.5	5.8	2.0	6.3	7.2	2.0	6.3	9.4	2.0	6.3
	6.5	6.4	2.0	6.3	7.5	2.0	6.3	10.9	2.0	6.3
	7.5	6.8	2.0	6.3	7.7	2.0	6.3	12.1	2.0	6.3
16	2.75	4.8	2.0	6.3	5.5	2.0	6.3	5.3	1.8	5.6
	3.5	4.9	2.0	6.3	6.2	2.0	6.3	6.7	2.0	6.3
	4.5	5.3	2.0	6.3	6.5	2.0	6.3	8.3	2.0	6.3
	5.5	5.7	2.0	6.3	6.7	2.0	6.3	9.5	2.0	6.3
	6.5	6.0	2.0	6.3	6.7	2.0	6.3	10.6	2.0	6.3
	7.5	6.3	2.0	6.3	6.8	2.0	6.3	11.4	2.0	6.3
12	2.75	4.5	2.0	6.3	2.1	2.0	4.9	5.3	1.8	5.6
	3.5	4.8	2.0	6.3	3.3	2.0	6.3	6.7	2.0	6.3
	4.5	5.0	2.0	6.3	3.9	2.0	6.3	8.0	2.0	6.3
	5.5	5.0	2.0	6.3	4.3	2.0	6.3	8.7	2.0	6.3
	6.5	5.1	2.0	6.3	4.6	2.0	6.3	9.2	2.0	6.3
	7.5	5.1	2.0	6.3	4.7	2.0	6.3	9.5	2.0	6.3

**NOTES FOR LOAD TABLES**

1. Loads listed in Tables 1 through 6 are based on a uniform soil bearing analysis using a simplified elastic soil procedure where the soil is assumed to act as a line of springs spaced one foot apart along the length with resistance directly proportional to settlement. (Similar to the subgrade modulus procedures for slab and paving design, except, with higher deflections allowed).

Type "A" (SGM-1) soil has a spring constant of 144 pounds per square foot, per inch settlement. Type "B" (SGM-3) soil has a spring constant of 432 pounds per square foot, per inch of settlement. Type "C" (SGM-5) soil has a spring constant of 720 pounds per square foot, per inch of settlement.

2. Loads listed in Table 7 are based on normal simple span beam design methods. Adequate bearing must be provided at the ends to support the loads.

3. Load duration - Loads listed in all tables are based on a stress increase of 1/3 (33 1/3%) for short duration loading. Where stresses govern the load, applied long term loads should be reduced accordingly and as much as 1/3 less for long term loading or frequent cycles of loading.

4. Load distribution - Load Tables are based on a unit width one foot wide perpendicular to the length. Loads can be assumed distributed over more than one foot depending on the type of load and loading conditions.

5. Edge loading - Load cases 4, 5, & 6 as shown in the load diagrams, are based on off-center loading. Under edge loading conditions the unloaded end of the member will deflect upward and should be considered when using edge loading.

**Table V-B  
Load Criteria (offset loading)  
Uniform Bearing On Soil Type "B"**

Load Per Linear Foot Of Width, K = Kip = 1,000 Lbs

Length	Thickness	Load Case 4			Load Case 5			Load Case 6		
Feet	Inches	P Load Kips	Defl. Inches	Bearing PSI	P Load Kips	Defl. Inches	Bearing PSI	P Load Kips	Defl. Inches	Bearing PSI
24	2.75	4.7	2.0	6.3	5.5	2.0	6.3	4.8	2.0	6.3
	3.5	5.0	2.0	6.3	6.1	2.0	6.3	5.7	2.0	6.3
	4.5	5.1	2.0	6.3	6.3	2.0	6.3	5.3	2.0	6.3
	5.5	5.2	2.0	6.3	6.2	2.0	6.3	5.0	2.0	6.3
	6.5	5.0	2.0	6.3	6.0	2.0	6.3	4.9	2.0	6.3
	7.5	4.7	2.0	6.3	5.9	2.0	6.3	4.8	2.0	6.3
20	2.75	4.7	2.0	6.3	5.5	2.0	6.3	4.8	2.0	6.3
	3.5	4.9	2.0	6.3	6.1	2.0	6.3	5.7	2.0	6.3
	4.5	5.0	2.0	6.3	6.2	2.0	6.3	5.2	2.0	6.3
	5.5	5.1	2.0	6.3	6.2	2.0	6.3	5.0	2.0	6.3
	6.5	4.9	2.0	6.3	6.0	2.0	6.3	4.9	2.0	6.3
	7.5	4.7	2.0	6.3	5.8	2.0	6.3	4.8	2.0	6.3
16	2.75	2.1	2.0	5.6	2.1	2.0	4.9	1.0	2.0	4.2
	3.5	2.8	2.0	6.3	3.1	2.0	6.3	2.2	2.0	6.3
	4.5	2.9	2.0	6.3	3.4	2.0	6.3	2.2	2.0	6.3
	5.5	2.9	2.0	6.3	3.6	2.0	6.3	2.2	2.0	6.3
	6.5	2.9	2.0	6.3	3.7	2.0	6.3	2.2	2.0	6.3
	7.5	2.9	2.0	6.3	3.7	2.0	6.3	2.2	2.0	6.3
12	2.75	2.1	2.0	5.6	2.1	2.0	4.9	1.0	2.0	4.2
	3.5	2.9	2.0	6.3	3.4	2.0	6.3	2.2	2.0	6.3
	4.5	2.9	2.0	6.3	3.9	2.0	6.3	2.2	2.0	6.3
	5.5	2.9	2.0	6.3	4.3	2.0	6.3	2.2	2.0	6.3
	6.5	2.9	2.0	6.3	4.6	2.0	6.3	2.2	2.0	6.3
	7.5	2.9	2.0	6.3	4.7	2.0	6.3	2.2	2.0	6.3

**Determining Loads**

Load tables are subject to interpretation and use for a variety of conditions. For load cases where uniform bearing is used: first the soil strength should be estimated and then using the tables for the various soil types and the load case that compares closest to the load conditions, the thickness and length can be selected; alternatively, for an existing thickness and length the estimated load resistance can be determined from the Tables.

Soil Type "A" (SGM-1) is soft soil and in theory a 200 lb person standing on a one foot by one foot (1ft<sup>2</sup>) block would settle into the surface 1/8".

For Soil Type "B" (SGM-3) the same 200 lbs on a one foot square would settle 7/16".

For Soil Type "C" (SGM-5) the same 200 lbs on a one foot square would settle 1/4"±.

For estimating soil strength using simplified bearing tests as described above, results should be based on incremental loads. Divide the resulting pressure in pounds per square inch by the settlement, and the results averaged to determine an estimated SGM.

For areas where geotechnical reports are required the geotechnical engineering should be requested to provide an estimated bearing capacity of the bearing strata, and if practical, in the form of subgrade modulus for settlement estimated in the range of one to two inches.

**Table VI-A**  
**Load Criteria (centered loading)**  
**Uniform Bearing On Soil Type "C"**

Load Per Linear Foot Of Width, K = Kip = 1,000 Lbs

Length	Thickness	Load Case 1			Load Case 2			Load Case 3		
Feet	Inches	P Load Kips	Defl. Inches	Bearing PSI	P Load Kips	Defl. Inches	Bearing PSI	P Load Kips	Defl. Inches	Bearing PSI
24	2.75	7.7	2.0	9.7	6.7	1.4	6.9	6.0	1.4	6.9
	3.5	8.2	2.0	9.7	10.0	1.9	9.7	8.6	1.6	8.3
	4.5	8.3	2.0	9.7	11.0	2.0	9.7	11.3	1.9	9.7
	5.5	9.0	2.0	9.7	12.0	2.0	9.7	14.3	2.0	9.7
	6.5	9.8	2.0	9.7	12.1	2.0	9.7	15.9	2.0	9.7
	7.5	10.4	2.0	9.7	12.5	2.0	9.7	18.0	2.0	9.7
20	2.75	7.7	2.0	9.7	6.7	1.4	6.9	6.0	1.4	6.9
	3.5	8.0	2.0	9.7	9.8	1.9	9.7	8.2	1.6	8.3
	4.5	8.3	2.0	9.7	11.3	2.0	9.7	11.4	1.9	9.7
	5.5	9.0	2.0	9.7	11.8	2.0	9.7	14.2	2.0	9.7
	6.5	9.6	2.0	9.7	12.1	2.0	9.7	16.0	2.0	9.7
	7.5	10.4	2.0	9.7	12.5	2.0	9.7	17.8	2.0	9.7
16	2.75	7.6	2.0	9.7	7.7	1.8	9.0	6.0	1.4	6.9
	3.5	7.9	2.0	9.7	9.9	2.0	9.7	8.2	1.6	8.3
	4.5	8.4	2.0	9.7	10.5	2.0	9.7	10.9	1.8	9.7
	5.5	9.0	2.0	9.7	11.0	2.0	9.7	14.0	2.0	9.7
	6.5	9.6	2.0	9.7	11.1	2.0	9.7	15.9	2.0	9.7
	7.5	10.0	2.0	9.7	11.2	2.0	9.7	17.1	2.0	9.7
12	2.75	7.3	2.0	9.7	3.2	2.0	8.3	6.0	1.4	6.9
	3.5	8.0	2.0	9.7	5.0	2.0	9.7	7.9	1.6	8.3
	4.5	8.2	2.0	9.7	5.9	2.0	9.7	11.3	1.9	9.7
	5.5	8.3	2.0	9.7	6.7	2.0	9.7	13.4	2.0	9.7
	6.5	8.4	2.0	9.7	7.3	2.0	9.7	14.7	2.0	9.7
	7.5	8.5	2.0	9.7	7.7	2.0	9.7	15.4	2.0	9.7

**NOTES FOR LOAD TABLES**

1. Loads listed in Tables 1 through 6 are based on a uniform soil bearing analysis using a simplified elastic soil procedure where the soil is assumed to act as a line of springs spaced one foot apart along the length with resistance directly proportional to settlement. (Similar to the subgrade modulus procedures for slab and paving design, except, with higher deflections allowed).

Type "A" (SGM-1) soil has a spring constant of 144 pounds per square foot, per inch settlement. Type "B" (SGM-3) soil has a spring constant of 432 pounds per square foot, per inch of settlement. Type "C" (SGM-5) soil has a spring constant of 720 pounds per square foot, per inch of settlement.

2. Loads listed in Table 7 are based on normal simple span beam design methods. Adequate bearing must be provided at the ends to support the loads.

3. Load duration - Loads listed in all tables are based on a stress increase of 1/3 (33 1/3%) for short duration loading. Where stresses govern the load, applied long term loads should be reduced accordingly and as much as 1/3 less for long term loading or frequent cycles of loading.

4. Load distribution - Load Tables are based on a unit width one foot wide perpendicular to the length. Loads can be assumed distributed over more than one foot depending on the type of load and loading conditions.

5. Edge loading - Load cases 4, 5, & 6 as shown in the load diagrams, are based on off-center loading. Under edge loading conditions the unloaded end of the member will deflect upward and should be considered when using edge loading.

**Table VI-B  
Load Criteria (offset loading)  
Uniform Bearing On Soil Type "C"**

Load Per Linear Foot Of Width, K = Kip = 1,000 Lbs

Length	Thickness	Load Case 4			Load Case 5			Load Case 6		
Feet	Inches	P Load Kips	Defl. Inches	Bearing PSI	P Load Kips	Defl. Inches	Bearing PSI	P Load Kips	Defl. Inches	Bearing PSI
24	2.75	7.4	2.0	9.7	6.7	1.6	7.6	6.9	1.8	9.0
	3.5	8.0	2.0	9.7	10.0	2.0	9.7	9.5	2.0	9.7
	4.5	8.4	2.0	9.7	10.6	2.0	9.7	9.6	2.0	9.7
	5.5	8.6	2.0	9.7	10.5	2.0	9.7	9.2	2.0	9.7
	6.5	8.7	2.0	9.7	10.4	2.0	9.7	8.3	2.0	9.7
	7.5	8.4	2.0	9.7	10.1	2.0	9.7	8.1	2.0	9.7
20	2.75	7.4	2.0	9.7	6.7	1.6	7.6	6.9	1.8	9.0
	3.5	8.1	2.0	9.7	9.9	2.0	9.7	9.5	2.0	9.7
	4.5	8.3	2.0	9.7	10.1	2.0	9.7	9.4	2.0	9.7
	5.5	8.5	2.0	9.7	10.5	2.0	9.7	8.5	2.0	9.7
	6.5	8.6	2.0	9.7	10.4	2.0	9.7	8.3	2.0	9.7
	7.5	8.3	2.0	9.7	10.1	2.0	9.7	8.0	2.0	9.7
16	2.75	3.3	2.0	9.0	3.2	2.0	8.3	1.7	2.0	6.9
	3.5	4.7	2.0	9.7	4.8	2.0	9.7	3.7	2.0	9.7
	4.5	4.8	2.0	9.7	5.3	2.0	9.7	3.6	2.0	9.7
	5.5	4.8	2.0	9.7	5.7	2.0	9.7	3.6	2.0	9.7
	6.5	4.8	2.0	9.7	5.9	2.0	9.7	3.6	2.0	9.7
	7.5	4.8	2.0	9.7	6.1	2.0	9.7	3.6	2.0	9.7
12	2.75	3.3	2.0	9.0	3.2	2.0	8.3	1.7	2.0	6.9
	3.5	4.7	2.0	9.7	5.1	2.0	9.7	3.7	2.0	9.7
	4.5	4.8	2.0	9.7	5.9	2.0	9.7	3.7	2.0	9.7
	5.5	4.8	2.0	9.7	6.7	2.0	9.7	3.7	2.0	9.7
	6.5	4.8	2.0	9.7	6.7	2.0	9.7	3.7	2.0	9.7
	7.5	4.9	2.0	9.7	7.6	2.0	9.7	3.7	2.0	9.7

**Determining Loads**

Load tables are subject to interpretation and use for a variety of conditions. For load cases where uniform bearing is used: first the soil strength should be estimated and then using the tables for the various soil types and the load case that compares closest to the load conditions, the thickness and length can be selected; alternatively, for an existing thickness and length the estimated load resistance can be determined from the Tables.

Soil Type "A" (SGM-1) is soft soil and in theory a 200 lb person standing on a one foot by one foot (1ft<sup>2</sup>) block would settle into the surface 1 3/8".

For Soil Type "B" (SGM-3) the same 200 lbs on a one foot square would settle 7/16".

For Soil Type "C" (SGM-5) the same 200 lbs on a one foot square would settle 1/4"±.

For estimating soil strength using simplified bearing tests as described above, results should be based on incremental loads. Divide the resulting pressure in pounds per square inch by the settlement, and the results averaged to determine an estimated SGM.

For areas where geotechnical reports are required the geotechnical engineering should be requested to provide an estimated bearing capacity of the bearing strata, and if practical, in the form of subgrade modulus for settlement estimated in the range of one to two inches.

# emtek Design Properties

$$\left. \begin{aligned} F_b &= 4123 \text{ psi} \\ F_v &= 379 \text{ psi} \end{aligned} \right\} \text{ W/ 1.33 Load Duration Factor}$$

$$E = 1.6 (10)^6 \text{ psi}$$

## Unit Section Properties

No	Size t x b	A In <sup>2</sup>	I In <sup>4</sup>	S In <sup>3</sup>	M <sub>A</sub> K-Ft	V <sub>A</sub> K
1	3.5" x 12"	42	42.875	24.50	8.418	10.612
2	4.5" x 12"	54	91.125	40.50	13.915	13.644
3	5.5" x 12"	66	166.375	60.50	20.787	16.676
4	6.5" x 12"	78	274.625	84.50	29.032	19.708
5	7.5" x 12"	90	412.875	112.50	38.653	22.740

$$A = t(b) \quad I = \frac{bt^3}{12} \quad S = \frac{bt^2}{6} \quad M_A = F_b S \quad V_A = \frac{F_v A}{1.5} \sim \left( \frac{FV \text{ lb}}{Q} \right)$$

K = KIP = 1000 lbs

M<sub>A</sub> = Allowable Moment W/1.33 Load Duration Factor

V<sub>A</sub> = Allowable Shear W/1.33

## Load Diagrams Bearing At Ends Of Span

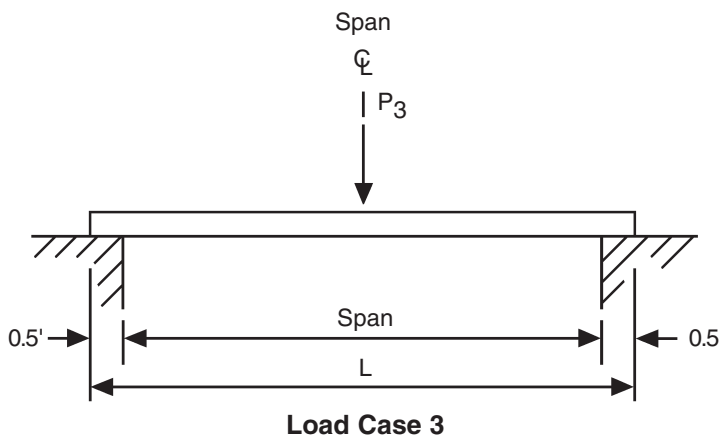
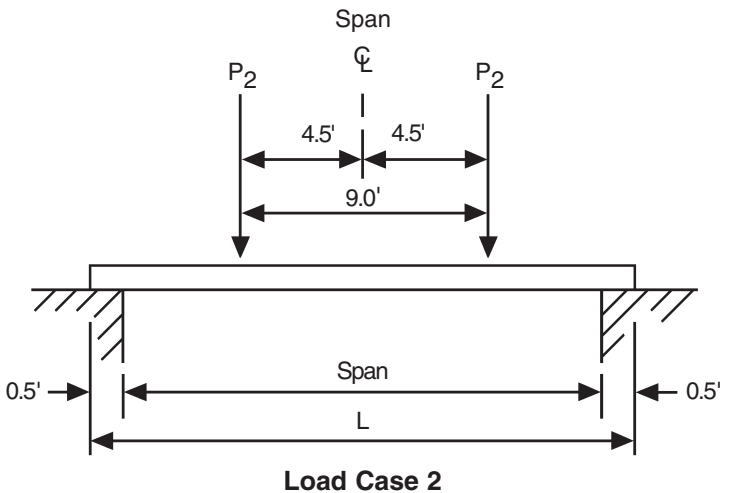
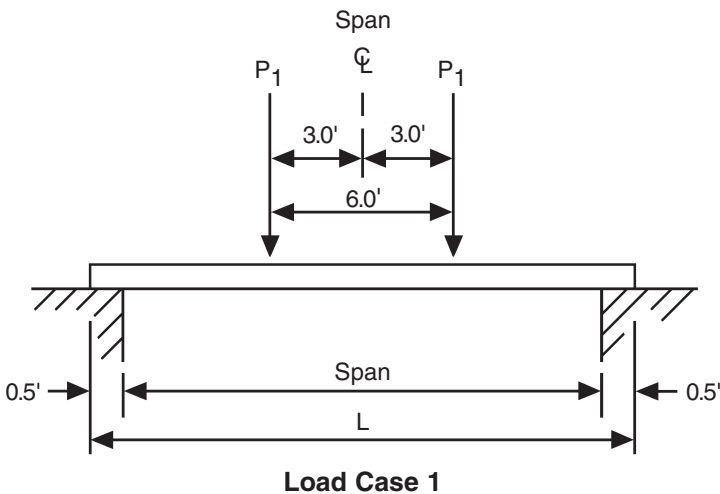

**Table VII  
Load Criteria  
Bearing At Ends Of Span**

Load Per Linear Foot Of Width, K = Kip = 1,000 Lbs

Length Feet	Span Feet	Thickness Inches		Load Case 1		Load Case 2		Load Case 3			
				P Load Kips	Defl. Inches	P Load Kips	Defl. Inches	P Load Kips	Defl. Inches		
24 L/120=2.4"	23	2.75	A	0.5	15.3	0.6	16.1	0.7	12.9		
			B	0.0	2.4	0.0	2.4	0.0	2.4		
		3.5	A	0.8	11.6	0.9	12.2	1.1	9.9		
			B	0.0	2.4	0.0	2.4	0.0	2.4		
		4.5	A	1.3	8.8	1.6	9.2	2.0	7.4		
			B	0.2	2.4	0.2	2.4	0.4	2.4		
		5.5	A	2.2	7.3	2.7	7.8	3.3	6.1		
			B	0.6	2.4	0.6	2.4	1.0	2.4		
		6.5	A	3.2	6.2	3.9	6.6	4.8	5.2		
			B	1.1	2.4	1.2	2.4	1.8	2.4		
		7.5	A	4.3	5.3	5.2	5.7	6.3	4.4		
			B	1.8	2.4	2.0	2.4	3.3	2.4		
		20 L/120=2.0"	19	2.75	A	0.7	10.8	0.9	11.5	1.0	8.8
					B	0.0	2.0	1.0	2.0	0.0	2.0
3.5	A			1.1	8.0	1.4	8.6	1.5	6.4		
	B			0.1	2.0	0.1	2.0	0.2	2.0		
4.5	A			1.9	6.2	2.5	6.6	2.6	5.0		
	B			0.5	2.0	0.6	2.0	0.8	2.0		
5.5	A			3.0	5.1	3.9	5.5	4.1	4.1		
	B			1.0	2.0	1.2	2.0	1.8	2.0		
6.5	A			4.3	4.4	5.6	4.7	5.8	3.5		
	B			1.8	2.0	2.2	2.0	3.2	2.0		
7.5	A			5.7	3.8	7.4	4.0	7.8	3.0		
	B			3.0	2.0	3.6	2.0	5.1	2.0		
16 L/120=1.6"	15			2.75	A	1.0	7.0	1.5	7.6	1.2	5.5
					B	0.2	1.6	0.2	1.6	0.1	1.6
		3.5	A	1.6	5.2	2.5	5.6	2.0	4.1		
			B	0.4	1.6	0.5	1.6	0.6	1.6		
		4.5	A	2.9	4.1	4.3	4.4	3.5	3.2		
			B	1.0	1.6	1.4	1.6	1.6	1.6		
		5.5	A	4.4	3.3	6.7	3.6	5.3	2.5		
			B	2.0	1.6	2.8	1.6	3.2	1.6		
		6.5	A	6.3	2.5	9.4	3.0	7.5	2.1		
			B	3.4	1.6	4.8	1.6	5.5	1.6		
		7.5	A	8.4	2.4	12.6	2.6	10.0	1.9		
			B	5.4	1.6	7.6	1.6	8.6	1.6		
		12 L/120=1.0"	11	2.75	A	1.8	4.1	4.0	4.4	1.7	3.0
					B	0.5	1.2	1.1	1.2	0.6	1.2
3.5	A			3.2	3.0	7.9	3.1	2.9	2.2		
	B			1.0	1.0	2.3	1.0	1.2	1.0		
4.5	A			5.4	2.3	13.4	2.4	4.9	1.7		
	B			2.2	1.0	5.2	1.0	2.8	1.0		
5.5	A			8.1	1.9	16.4	1.6	7.3	1.4		
	B			4.2	1.0	9.9	1.0	5.3	1.0		
6.5	A			11.4	1.6	19.4*	1.2	10.3	1.2		
	B			7.1	1.0	16.7	1.0	8.9	1.0		
7.5	A			15.3	1.4	22.4*	0.9	13.8	1.0		
	B			11.0	1.0	N/A	N/A	N/A	N/A		

\* Shear Stress Governs    A - Load & Deflection Based On Strength    B - Load for L/120 Deflection As Listed

$$\left. \begin{aligned} F_b &= 4123 \text{ psi} \\ F_v &= 379 \text{ psi} \end{aligned} \right\} \text{ W/ 1.33 Load Duration Factor}$$

$$E = 1.6 (10)^6 \text{ psi}$$

Unit Section Properties						
No	Size t x b	A In <sup>2</sup>	I <sub>X'</sub> <sup>1</sup> In <sup>4</sup>	S <sub>X'</sub> <sup>1</sup> In <sup>3</sup>	M <sub>A</sub> <sup>11</sup> K-Ft	V <sub>A</sub> <sup>1</sup> K
1	8" x 12"	96	512	128	43.98	24.3
2	12" x 12"	144	1728	288	98.95	36.4
3	16" x 12"	192	4096	512	175.9	48.5
4	24" x 12"	288	13824	1152	395.8	72.8

$$A = t(b) \quad I = \frac{bt^3}{12} \quad S = \frac{bt^2}{6} \quad M_A = F_b S \quad V_A = \frac{F_v A}{1.5} \sim \left( \frac{FV \text{ lb}}{Q} \right)$$

K = KIP = 1000 lbs

M<sub>A</sub> = Allowable Moment W/1.33 Load Duration Factor

V<sub>A</sub> = Allowable Shear W/1.33

SVE Portable Roadway Systems

emtek mats

## Mat Load Diagrams

Lengths (Ft)      12, 16, 20, 24, 28, 32, 36, 40

Track Pad Widths (Ft)      3, 4, 5, 6

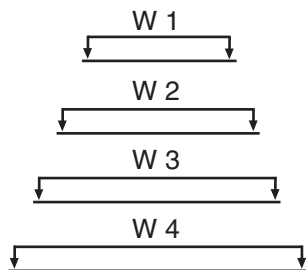

- Track Pad Width 3' LC - 1
- Track Pad Width 4' LC - 2
- Track Pad Width 5' LC - 3
- Track Pad Width 6' LC - 4

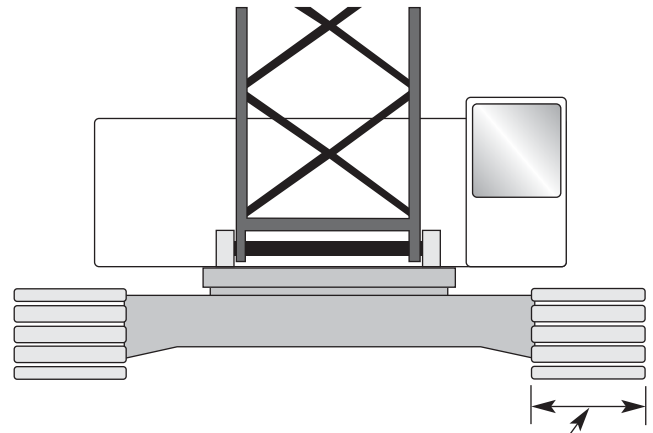

**Table VIII  
Heavy Lift Sections**

Mat Thickness (Inches)	Mat Length (Feet)	Load Track Width (Feet)	Unit Load K/SF	Soil Reaction K(K/SF)	Estimated Deflection (Inches)	Control Stress M or V
8	16 (I)	3	20.1	8.07	1.00	M
		4	17.4	9.00	1.13	M
		5	16.1	10.10	1.26	M
		6	15.9	11.42	1.43	M
	12	3	20.0	7.92	0.99	M
		4	17.3	8.89	1.12	M
		5	16.2	10.06	1.26	M
		6	16.2	11.53	1.44	M
12	20 (I)	3	29.9	8.94	1.12	M
		4	24.7	9.72	1.21	M
		5	21.9	10.55	1.31	M
		6	20.3	11.45	1.43	M
	16	3	29.9	8.95	1.12	M
		4	24.9	9.75	1.19	M
		5	22.1	10.62	1.29	M
		6	20.7	11.62	1.43	M
	12	3	34.8	10.72	1.34	V
		4	26.0	10.53	1.31	V
		5	27.5	13.67	1.70	M
		6	22.9	13.42	1.67	V
16	20 (I)	3	40.7	9.93	1.24	M
		4	31.8	10.23	1.27	V
		5	28.6	11.33	1.42	M
		6	25.9	12.13	1.51	M
	16	3	43.0	10.84	1.36	V
		4	32.2	10.73	1.34	V
		5	32.3	13.28	1.66	V
		6	26.8	13.00	1.63	V
	12	3	45.7	13.47	1.68	V
		4	34.3	13.37	1.67	V
		5	37.1	17.98	2.24	V
		6	30.7	17.71	2.21	V

Table VIII continues on Page 21.

**NOTES**

1. Longer mats have same capacity for soil conditions and mat thickness.
2. Loads listed are based on a uniform soil bearing analysis using a simplified elastic soil procedure where the soil is assumed to act as a line of springs spaced one foot apart along the length with resistance directly proportional to settlement. (Similar to the subgrade modulus procedures for slab and paving design, except, with higher deflections allowed). All figures are based on Subgrade Modulus of 8K/ft<sup>2</sup>/in.

**Table VIII (Cont'd)  
Heavy Lift Sections**

Mat Thickness (Inches)	Mat Length (Feet)	Load Track Width (Feet)	Unit Load K/SF	Soil Reaction K(K/SF)	Estimated Deflection (Inches)	Control Stress M or V
24	32 (1)	3	59.1	10.71	1.34	V
		4	44.3	10.63	1.33	V
		5	41.2	12.25	1.53	V
		6	34.1	12.09	1.52	V
	28	3	59.1	10.71	1.35	V
		4	44.3	10.63	1.33	V
		5	41.2	12.25	1.53	V
		6	34.1	12.09	1.52	V
	24	3	59.3	10.84	1.35	V
		4	44.4	10.74	1.35	V
		5	41.3	12.40	1.55	V
		6	34.3	12.24	1.52	V
	20	3	59.9	11.45	1.44	V
		4	44.9	11.40	1.42	V
		5	42.2	13.31	1.66	V
		6	35.1	13.16	1.64	V
	16	3	61.9	13.47	1.68	V
		4	46.4	13.41	1.67	V
		5	45.1	16.24	2.02	V
		6	37.6	16.12	2.02	V
	12	3	67.4	18.85	2.35	V
		4	50.4	18.75	2.34	V
		5	54.0	25.04	3.13	V
		6	44.94	24.93	3.11	V

**NOTES**

1. Longer mats have same capacity for soil conditions and mat thickness.
2. Loads listed are based on a uniform soil bearing analysis using a simplified elastic soil procedure where the soil is assumed to act as a line of springs spaced one foot apart along the length with resistance directly proportional to settlement. (Similar to the subgrade modulus procedures for slab and paving design, except, with higher deflections allowed). All figures are based on Subgrade Modulus of 8K/ft<sup>2</sup>/in.



# NOTES & CALCULATIONS

A large grid area for notes and calculations, consisting of 20 columns and 30 rows of small squares.





PORTABLE ROADWAY SYSTEMS, INC.

6128-F Brookshire Blvd.  
Charlotte, NC 28216

800-762-8267  
Fax 704-398-0540

e-mail [sales@mudtraks.com](mailto:sales@mudtraks.com)  
**[www.mudtraks.com](http://www.mudtraks.com)**